



## G500 SERIES MICROSCOPE

# OPERATION MANUAL

For use with MFR# G502, G502T, G504, G504T, G505, G505T.



United Products & Instruments, Inc.

182 Ridge Road, Suite E

Dayton, NJ 08810 USA

T. 732-274-1155; F. 732-274-1151

[www.unicosci.com](http://www.unicosci.com)

[info@unicosci.com](mailto:info@unicosci.com)

## UNICO G500 SERIES MICROSCOPE

Thank you for selecting the UNICO G500 Series Microscope. This precisely built, durable microscope should give years of service to even the busiest office or laboratory. Please read this manual carefully before you operate the microscope. If ever you require an additional accessory or spare part, please contact your local distributor, or you can contact UNICO for the name of the nearest distributor.

### UNPACKING AND INSTALLATION

The microscope is packed in cushioning styrofoam in a box for maximum protection during shipping. Please examine the unit upon receiving and retain all packing until the unit has been tested. The warranty excludes any damage caused by shipping. Inspect for any possible shipping damage. If you note any damage, please contact your representative. Save the original packaging. If it becomes necessary to return the unit to us, we ask that it be returned in the original packaging. Unpack the shipping box carefully and verify that the shipment is complete.

It should include the following items:

|                       |                                    |
|-----------------------|------------------------------------|
| G500 Microscope stand | 1pc.                               |
| Condenser             | 1pc.                               |
| Binocular head        | 1pc.                               |
| 10x eyepieces         | 2pc.                               |
| Objectives            | 4pc. ( May vary by specific model) |
| Replacement fuse      | 1pc.                               |
| Dust cover            | 1pc.                               |
| Operation Manual      | 1pc.                               |

If any parts are missing, please contact your sales representative or call UNICO customer service at 732-274-1155 or e-mail us at [info@unicosci.com](mailto:info@unicosci.com). Please have the serial #, date of purchase and name of supplier available.

Remove the microscope from its packaging and place it on a sturdy, clean and dry surface. Do not touch optical surfaces with your bare hands. The following diagram showing components that needs to be installed.

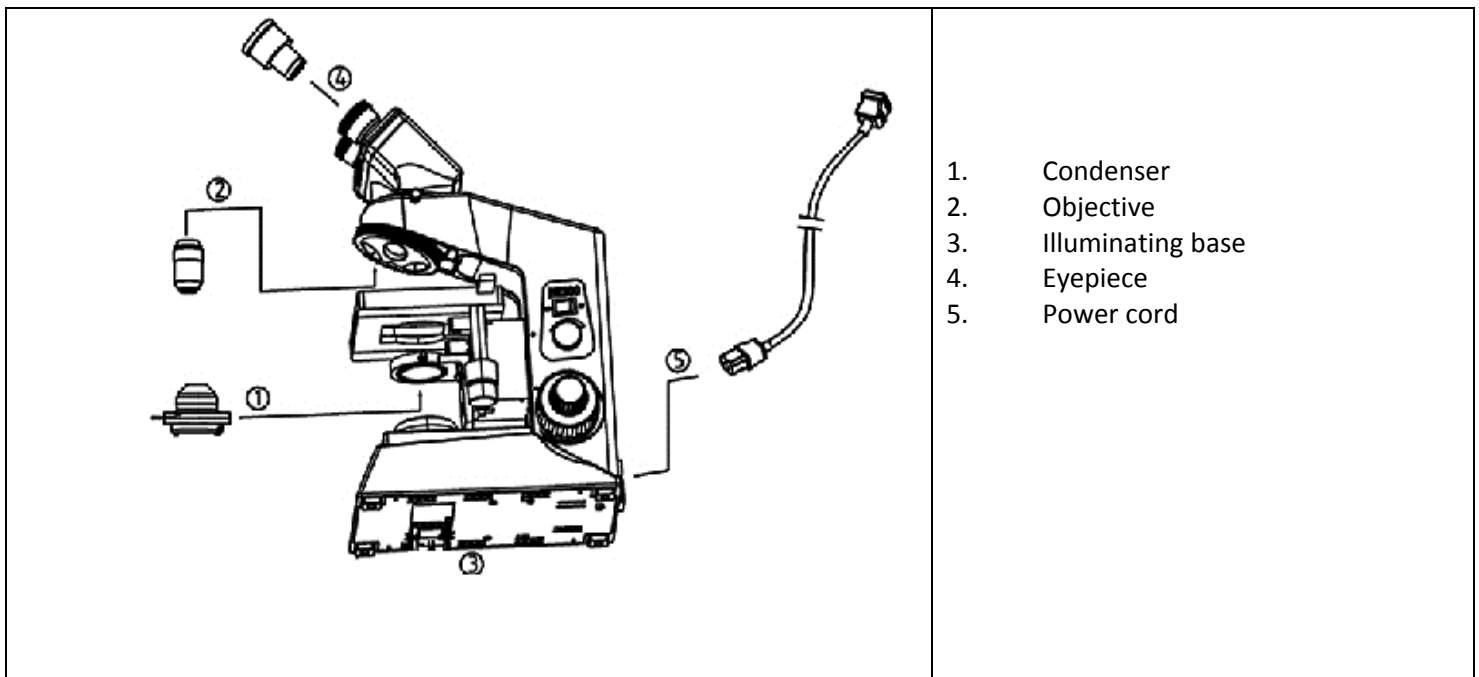

### INSTALLING CONDENSER

- Turn the coarse focus knob (① in Figure 5) to raise the stage to its highest position.
- Turn the condenser holder knob (② in Figure 5) to lower the condenser holder to its lowest position.
- Loosen the condenser locking screw on the holder (③ in Figure 5). Slide the condenser into the holder. The guiding screw on the back side should go into the slot of the condenser holder.
- Tighten the locking screw (③) to secure the condenser in place. Use the condenser holder knob (②) to move the condenser up to the highest position.

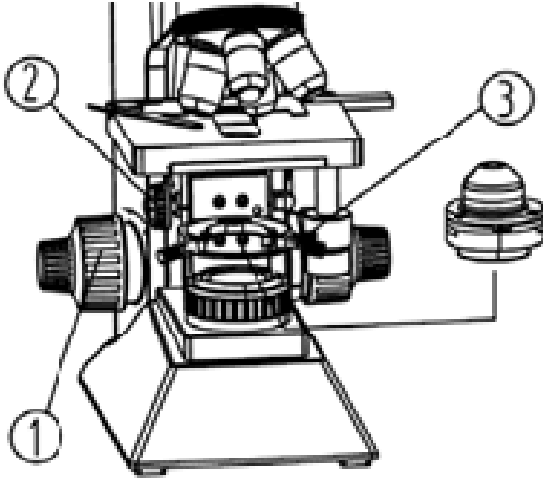

Fig. 5 Installing Condenser

### INSTALLING OBJECTIVES

Microscope objectives may be pre-installed for your convenience. If not please follow instructions below.

- Turn the coarse knob (① in Figure 6) to move the stage down for easy access to the nosepiece.
- Screw in the objectives (② in Figure 6) from lower power to higher power moving clockwise.

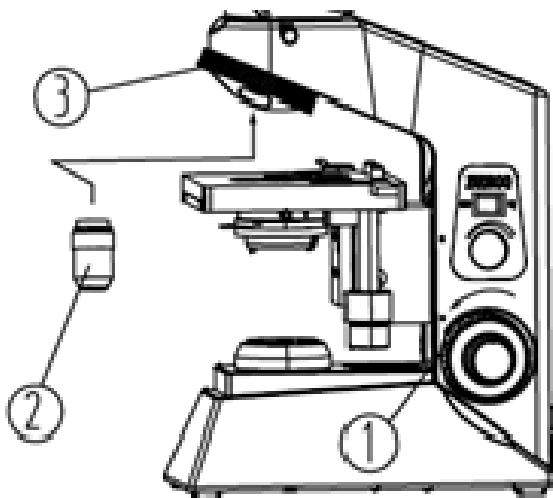

Fig.6 Installing Objectives

### INSTALLING EYEPIECES

Remove the plastic caps from the eyepiece tube holes and store them in case of service needs. Slide the eyepieces into the eyepiece tubes. Set diopter rings to 0.

Plug in the power cord into the power inlet at the back of the microscope to finish installation.

## OPERATION

Set the power switch ① to ON position (Fig.7). Use the brightness knob ② to adjust the brightness.

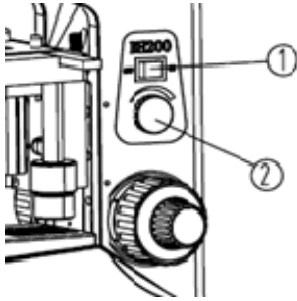

Fig. 7 Illumination

Push back on the finger assembly ① and place the slide ② on the mechanical stage (Fig.8). Release finger assembly carefully not to damage the slide. Make sure the cover glass is on top of the slide. Use the mechanical stage controls ③ to center the slide under an objective.

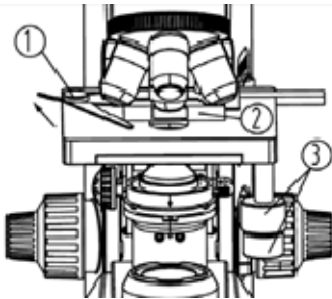

Fig. 8 Slide Holder

Turn the nosepiece to set the 4X objective into working position. Use the coarse focusing knob to focus the microscope. Rotate the diopter rings ① (Fig.9) on both the left and right eyepiece tubes so that the "0" on the diopter ring is set at the center line mark ② on the eyepiece tubes.

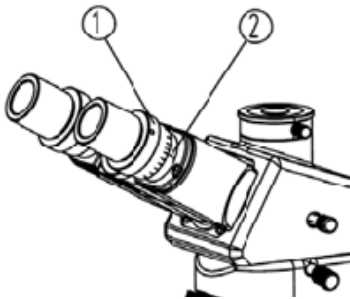

Fig. 9 Diopter Adjustment

Using your right eye only turn the coarse focusing knob ① (Fig.10) and then the fine focusing knob ② to bring the slide into sharp focus viewing through the right eyepiece only. Using your left eye only rotate the left diopter until the image is sharp focus without touching focusing knobs. You should now be in sharp focus with both your right and left eyes. Note your personal diopter setting for future use.

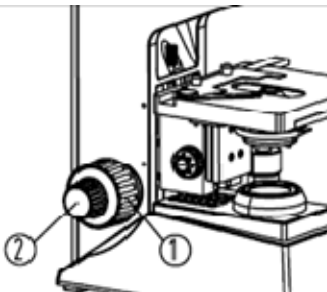

Fig.10 Coarse and Fine Focusing knobs

Rotate the nosepiece to bring a higher power objective into light path. Use fine focusing adjustment knob to bring the image into focus (100X objective requires immersion oil).

#### FOCUSING TENSION ADJUSTMENT

The focusing tension adjustment ring ① (Fig.11) is located on the right side between the stand and the coarse focusing knob. Use the ring if one of the following conditions is true:

- The coarse adjustment is difficult to turn, too tight or uncomfortable to use
- The image drops out of focal plane after focusing
- The stage slowly sinks down on its own, without touching the focus controls

Turn the ring clockwise will increase the tension. Turn the ring counterclockwise to release the tension.

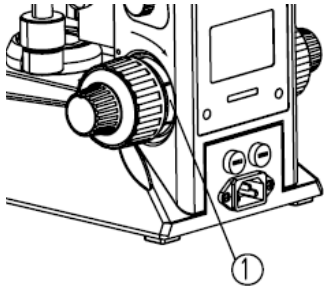

Fig.11 Focusing Tension Adjustment ring

#### INTERPUPILLARY DISTANCE ADJUSTMENT

Look into the eyepieces and move the eyepiece tubes ① (Fig.12) together or apart until you see only one complete circle of light. The interpupillary distance adjustable range is 50-76mm.

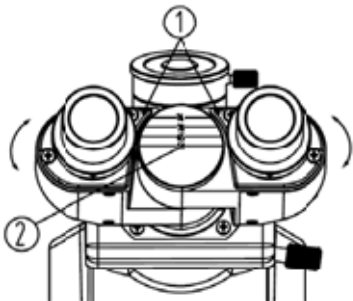

Fig. 12 Interpupillary Distance Adjustment

#### CENTERING THE CONDENSER

- 1) Move condenser all the way up by turning the condenser knob ① (Fig. 13). Bring the 10X objective into light path.
- 3) Rotate the field diaphragm ring ② counterclockwise to close the diaphragm. You should see the narrow light spot in the field of view (Fig. 14-A). Slowly move the condenser down until the light spot is in sharp focus.
- 5) Use the centering screws ③ (Fig.13) to bring the light spot to the center of the field of view if necessary. (Fig. 14-B)
- 6) Slowly open the field diaphragm. The light spot should remain centered in the field of view (Fig.14-C).

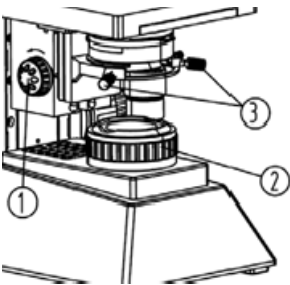

Fig.13 Centering the Condenser

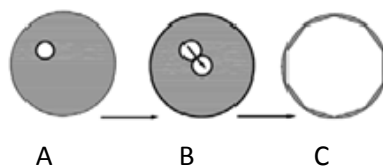

Fig.14 Field Diaphragm Light spot

### USING FIELD DIAPHRAGM (KOEHLER)

The field diaphragm (KoeHLer Iris) can restrict the light coming from the illuminator to the condenser. This will help to block the scattering of light and improve contrast. This tool is particularly helpful when viewing unstained specimens, or using Phase Contrast. Rotate ring ② (Fig.13) as necessary observing contrast change.

### USING CONDENSER IRIS DIAPHRAGM

The Iris diaphragm in the condenser controls and determines aperture of the illumination to the objectives. Only when the aperture of the illumination is properly set for an objective, can you get the best resolution and contrast of the image; and the depth of field.

The diaphragm aperture ① (Fig. 15) of the condenser is set at 70-80% of objective aperture ② (Fig. 15) for best result. You can observe this by removing the eyepiece and viewing through eyepiece tube. Slide the Iris setting lever ③ (Fig.16) to match the power of the objective in use. The Iris is graduated ④ ( Fig.16) with 4/10/40/100X & Ph (phase)

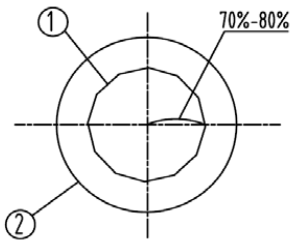

Fig.15 Objective Aperture and Aperture Diaphragm

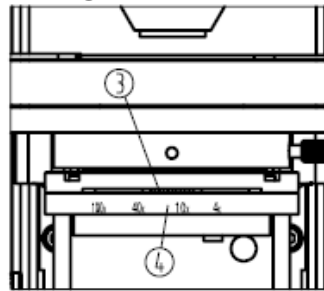

Fig. 16 Iris Diaphragm Setting

### USING 100X OIL IMMERSION OBJECTIVE

- Use the 4X or 10X objective to find and center the image. Place one drop of immersion oil on the slide.
- Turn the nosepiece COUNTER-CLOCKWISE to bring the objective 100X into light path. Make sure 40X objective is not passing through the oil. Oil will damage 40X objective.
- Use the fine focusing knob to bring the image into focus.
- Make sure there are no bubbles inside oil as they will affect image quality. Rotate the nosepiece back and forth softly to allow the 100X objective lens to swing through the oil to smooth out the bubbles.
- After each use clean the objective immediately to prevent damage to the objective.

### FOCUSING PROCEDURE

- Bring the 4x objective into working position. Set Iris diaphragm to 4x position. As you bring the objective into place, will feel a “stop” (clicking) when the objective is positioned properly. Use the coarse and fine adjustment knobs to locate the image and bring the 4x objective into focus.
- Move the 10x objective into place. Set Iris diaphragm to 10x position. Minor coarse adjustment may be needed yet the fine focusing knob is needed to bring the 10x objective into focus.
- Rotate to the 40x objective. Set Iris diaphragm to 40x position. Focus with fine focusing knob for the best image. Adjust field diaphragm for best contrast.

### USING FILTERS

Filter can make the background of the image more suitable for observation, depending on the specimen. There are blue, green, yellow and neutral filters available. Select the proper filter for your specific application. Place the filter on top of the light housing ① (Fig. 18)

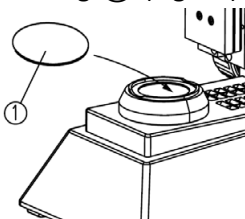

Fig. 18 Filter

## USING TRINOCULAR HEAD

An 80/20 beam splitter is built-into the Trinocular head. When the slide lever ① is pushed in, 100% of the light beam enters the eyepieces tubes and it functions as a Binocular head. When the lever ① is pulled out, the light beam is split with 80% to the binocular and 20% to the vertical tube/port for video and/or photographic purposes.

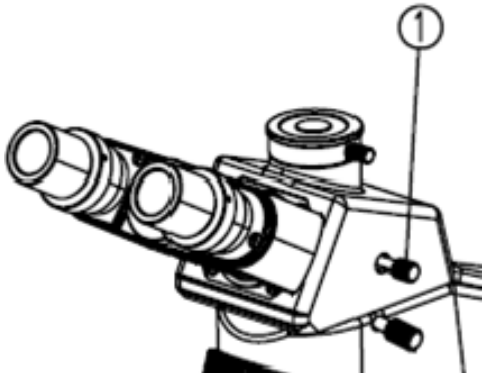

Fig. 19 Trinocular Head

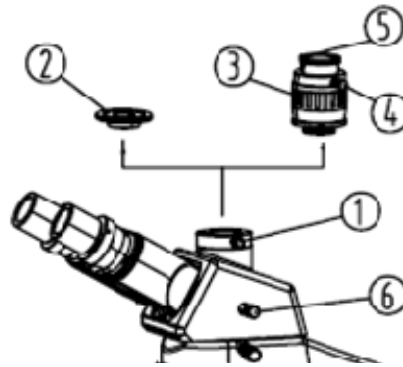

Fig.20 C-Mount Adapter

Optional C-Mount adapter needs to be installed to allow use of the camera with the microscope.

- Loosen the locking-screw ① (Fig.20) on trinocular head and take off the cap ② on the vertical tube/port.
- Remove the cap on the C-mount ③ and put the adapter into the port and lock in-place with the screw ④.
- The C-mount adapter's top threaded mount ⑤ is a standard external C-thread. Your video camera should have an internal C-thread. Thread your camera onto the C-mount adapter.
- Loosen the locking screw ④ to rotate your camera until the image is properly oriented. The C-mount adapter includes an independent focusing ring; adjust for the best image.
- Push back the beam splitter slide lever ⑥ when not using the vertical port for video/photography.

## PHASE CONTRAST OPERATION

UNICO G500 series microscope offers model G505 featuring 10/20/40/100 Plan Phase objectives combined with 10X/40X and 20X/100X Phase Annulus sliders. The objectives and sliders can be added separately to any configuration of the G500 series microscope. To use phase contrast:

- Select phase contrast objective suitable for your application and bring it into the light path. If not installed refer to the objective installation section of this manual. You may need to remove one or more of the already installed objectives if there is no more available slots on the nosepiece.
- Remove blank slider from the condenser by pushing it from left to right. Insert phase annulus slider with annulus matching the desired objective. The center of the slider is designed to be used for brightfield microscopy. The left and right annuluses are marked with matching magnifications.
- Slide the Iris setting lever ③ (Fig.16) to PH position. Bring the matching annulus into the light path and proceed with the examination of your sample. Remember to change the annulus position when selecting another phase objective.

## SERVICE AND MAINTENANCE

- Always cover your microscope with the dust cover when not in use.
- When cleaning the lenses, use lens paper or a Q-tip dipped in lens cleaning solution.
- Excess immersion oil should be cleaned of at once. An alcohol pad is best for removing oil from the stage and on the other metal parts, but is not recommended for use on the lenses.
- Dust in the nosepiece or eyepiece tubes should be blown out using only filtered air. Canned air work well for this job. Whenever you remove an objective, we recommend that you place the plastic cap over the slot and put the objective back into the original plastic shipping container until ready to be placed back on the microscope. This will keep the objective safe from dust and other foreign matter.
- To keep your microscope in top condition for years, we recommend that you have the microscope professionally serviced once a year.

## FUSE REPLACEMENT

Turn the power switch off and disconnect the power cord from power outlet before replacing the fuse.

- Use a screw driver to remove the fuse cap ① from the fuse base ② (Fig.21) ;
- Replace with new fuse(s) of the same type and rating: 250V, 1A.
- Screw the fuse cap back. (Figure 24)

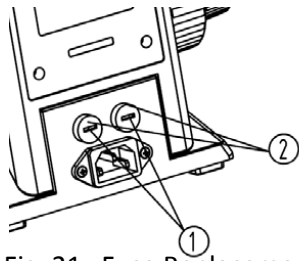

Fig. 21 Fuse Replacement

## LED REPLACEMENT

- Disconnect the power cord; allow the unit to cool down.
- Loosen the 4 locking screws that mount the bottom plate to the body.
- The LED assembly is mounted with the two-wire cable to the power supply PCB. Disconnect the connector from the power supply PCB. Then remove the LED assembly by loosening the two locking screws.
- Install a new LED assembly onto the bottom plate and re-plug the connector to the power supply PCB.
- Put the bottom plate back and lock in place with the screws.

## UNICO G500 SERIES MICROSCOPE SPECIFICATIONS

Optical system Color corrected optical system

Head Binocular 30°inclined, 360°rotatable, Trinocular with 80/20 beam splitter

Eyepieces High point plan eyepieces, FN 18mm, with eye-guards

Nosepiece Built-in 5-hole nosepiece

Focusing Coaxial coarse and fine focusing with movement range up to 28mm and resolution at 0.002mm

Stage Built-in Mechanical stage 140 x132mm; with movement range 76\*50mm and low X-Y adjustment knobs

Illumination LED illumination, 3 Watt with 90~240V wide range power supply.

Environment Altitude: under 2000m (under 7,000 ft.); Temp 5°C-35°C (41°F-95°F); Humidity: 80%

## Objective Specifications

| Magnification             | Numerical Aperture (N.A.) | Conjugate Distance (mm) | Par-focus Distance (mm) | Cover Glass (mm) | Ring Color |
|---------------------------|---------------------------|-------------------------|-------------------------|------------------|------------|
| Achromatic 4X             | 0.10                      | 195                     | 45                      | 0.17             | Red        |
| Achromatic 10X            | 0.25                      | 195                     | 45                      | 0.17             | Yellow     |
| Achromatic 40X(S)         | 0.65                      | 195                     | 45                      | 0.17             | Blue       |
| Achromatic 100X(OIL)      | 1.25                      | 195                     | 45                      | 0.17             | White      |
| Plan Achromatic 4X        | 0.10                      | 195                     | 45                      | 0.17             | Red        |
| Plan Achromatic 10X       | 0.25                      | 195                     | 45                      | 0.17             | Yellow     |
| Plan Achromatic 40X(S)    | 0.65                      | 195                     | 45                      | 0.17             | Blue       |
| Plan Achromatic 100X(OIL) | 1.25                      | 195                     | 45                      | 0.17             | White      |
| Plan Phase 10X            | 0.25                      | 195                     | 45                      | 0.17             | Yellow     |
| Plan Phase 20X            | 0.40                      | 195                     | 45                      | 0.17             | Green      |
| Plan Phase 40X            | 0.65                      | 195                     | 45                      | 0.17             | Blue       |
| Plan Phase 100X (Oil)     | 1.25                      | 195                     | 45                      | 0.17             | White      |



## TROUBLESHOOTING

| Problem  | Reason   | Solution  |
|--|--|---|
| <b>Optics</b>  |  |   |
| Not bright enough  | Field diaphragm is not open enough                                 | Open the field diaphragm more   |
|  | Condenser is too low   | Adjust the condenser position   |
|  | Condenser is not centered  | Center the condenser  |
|  | Beam splitter lever is pulled out                                  | Push back the lever (trinocular only)   |
| The edge of field of view is dark or not even                                  | Nosepiece is not at the right position                             | Turn the nosepiece to click into position   |
|  | Dust on condenser, objective or eyepiece                           | Clean the lens  |
| Stain on the field of view   | Stain on the specimen  | Prepare another specimen  |
|  | Stain on condenser, objective or eyepiece                          | Clean the lens  |
| Blurry Image   | No cover glass on the slide  | Add cover glass (0.17mm)  |
|  | The cover glass is too thick                                       | Use 0.17mm thickness cover glass  |
|  | Slide is upside down   | Turn the slide, cover slip up   |
|  | Oil on dry objective (i.e. 40X)                                    | Clean the lens of the objective   |
|  | No oil on the Oil objective (i.e. 100X)                            | Add immersion oil   |
|  | Iris diaphragm is not open properly                                | Adjust the Iris to get the best contrast  |
|  | Condenser is too low   | Adjust the condenser position   |
| One side of the image is dark or the image moves while focusing                | Condenser is not centered  | Center the condenser  |
|  | The mechanical stage is not level                                  | Check the stage, and table  |
| Eyes get tired easily  | Interpupillary is not set properly                                 | Adjust the interpupillary distance  |
|  | Diopter setting is not properly set                                | Set the diopter to fit your eyes  |
| <b>Mechanical</b>  |  |   |
| Unable to focus on higher magnification objectives                             | Slide is upside down with cover glass at the bottom                | Turn the slide with cover slip on top u   |
|  | Wrong cover glass is used  | Use 0.17mm thickness cover glass  |
| The objective touches slide while turning from lower to higher power objective | The slide is upside down   | Turn the slide with the cover slip on top   |
|  | The cover glass is too thick                                       | Use 0.17mm thickness cover glass  |
| The coarse knob is too tight   | The focusing tension setting is too tight                          | Readjust the tension setting  |
| The stage drifting down  | The focusing tension setting is too loose                          | Tight the focusing tension properly   |
| The stage can't move high enough   | The stage up-limit setting is low                                  | Readjust the up-limit setting   |
| The slide doesn't move smoothly  | The slide is not held properly                                     | Check and hold the slide properly   |
|  | The slide holder is loose or damaged                               | Check and/or repair the slide holder  |
| <b>Electronics</b>   |  |   |
| The light is not on  | No power   | Check the power cable and supply  |
|  | Power is on, LED not lighting up                                   | The LED power unit may be defective. Check the input and output and repair/replace it |
| Burn out the LED consistently  | Power to LED wrong   | Check the power output to the LED. Repair or replace the power supply                 |
| Not bright enough  | The brightness adjustment setting is not correct or malfunctioning | Check the brightness adjustment knob; repair or replace the rheostat.                 |
| Light flickers   | Malfunctioning power supply or loose wiring                        | Check the wiring; repair or replace the power supply unit                             |